



Mk5 SWP Single Wiper Plug with Integral Ball Seat

The SWP wiper plug is Weatherford's premium single wiper plug for displacement of cement through the ID of a liner. A major advantage of the SWP is its integral ball seat, used to activate hydraulic liner hangers and running tools. Typically the SWP is used in conjunction with Weatherford's jointed system; therefore, the plug does not move in relation to the liner until the SWP is launched.

The drillpipe dart (DPD) is released behind the cement. When it reaches the SWP, the DPD latches and seals into the inner body of the SWP. Differential pressure across the SWP then launches it from the plug adaptor. The SWP is displaced through the liner, acting as a mechanical barrier behind the cement. It then lands and latches in the landing collar, and pressure can be applied as required.

Applications

- Any liner for which a single-wiper plug is required

Features, Advantages and Benefits

- Integral ball seat is more reliable than landing collar ball seats, minimizing the potential for nonproductive time.
- When the integral ball seat is sheared, the pressure dissipates in the liner volume, greatly reducing the possibility of any formation damage related to hydraulic shock.
- High-strength design makes the SWP capable of withstanding high bump pressure.
- Several features help simplify or accelerate drill-out, saving rig time:
 - Anti-rotation devices prevent the SWP and DPD from rotating during drill-out of the landing collar.
 - The SWP is made of aluminum and elastomeric materials, making it PDC drillable.

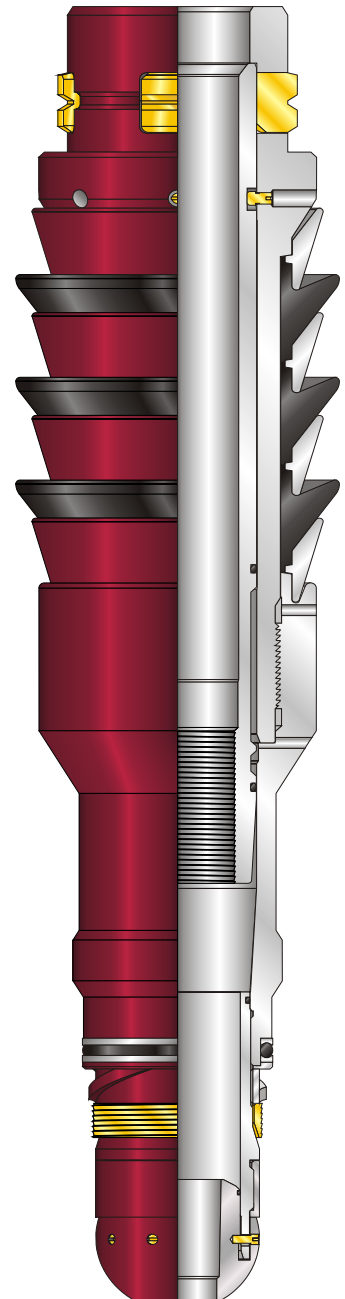



Mk5 SWP Single Wiper Plug with Integral Ball Seat

Features, Advantages and Benefits (continued)

- The SWP is locked to the running tool string by a set of profiled dogs rather than shear screws, reducing the risk of premature release and associated nonproductive time.
- Fin and backup ring configuration makes the HNBR fins capable of withstanding high differential pressure, enabling them to effectively wipe the liner ID and act as the lower packoff.

Specifications

- Contact an authorized Weatherford representative.

Options

- The SWP is available without the ball seat.
- A five-fin SWP is also available, further enhancing the already impressive wiping ability of the plug.